

AGM-600 Pit Bull

HIGH POWER ROCKET KIT

This kit contains all the parts necessary*
to build a flying high power rocket:

- 1) Pre-slotted main airframe
- 1) Pre-slotted boat tail
- 1) Nose cone
 - 1) Bulk plate w/ (2) 3/8" holes
 - 1) U-bolt with nuts and washer
- 4) Main fins
- 4) Canard fins
- 1) Piston ejection kit including:
 - 1) Piston body
 - 1) Piston strap
 - 1) Slotted bulk plate
 - 1) Kwik Link
- 1) Parachute
- 1) Motor mount tube (54mm)
- 1) Centering ring for boattail shoulder
- 1) Notched centering ring
- 1) Small centering ring
- 1) Nylon shock cord
- 2) Launch lugs
- 2) Decal sheets
- 1) Instruction booklet (this one!)

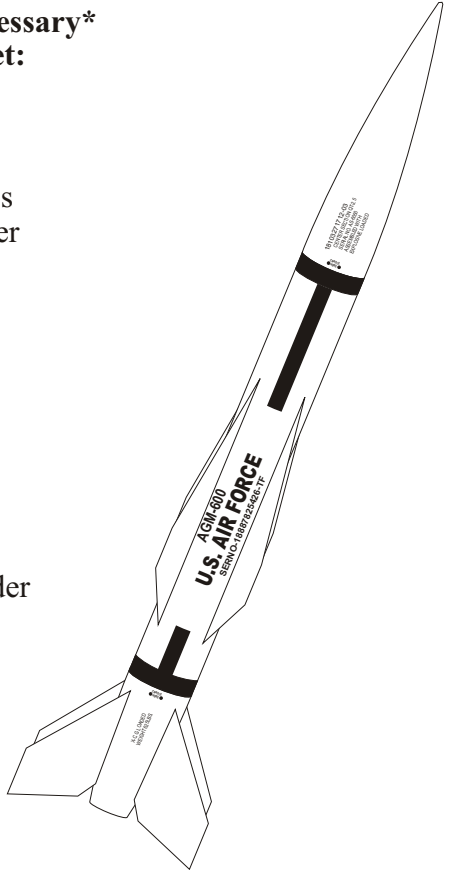

Please read and understand all instructions before building!

The center of pressure (CP) of this rocket is 65 inches from nose tip. After finishing your rocket, permanently mark the center of pressure on the airframe. After loading the rocket with a motor, make sure that the center of gravity (balancing point) is at least one body diameter forward of the center of pressure mark. The center of gravity can be moved forward by adding weight to the nose cone.



Basic Construction FAQ

General Assembly Tips

Make sure you lightly sand any area to be bonded! This includes fins, airframe (inside and out), motor mount, etc. This is important to get a good "bite" on the materials for the epoxy, and is especially important in high-stress applications. It takes very little extra time to do this, and the sanding dramatically improves overall strength. Don't skip the sanding!

1. After filling tube seams as described in the Airframes FAQ under *Filling Phenolic Tube Spiral Seams*, assemble according to the kit instructions. We recommend using a quality epoxy in all gluing procedures (see the Adhesives FAQ for details). Be sure to apply epoxy fillets to all critical areas, especially the fins.
2. Now is the time to touch up any dings that may have occurred during assembly. Dab a bit of automotive spot putty on the affected area, let dry and sand smooth.
3. Fill imperfections in fiberglass cones with Bondo, automotive spot putty, etc. Scuff fiberglass cones with fine sandpaper before painting.
4. Spray the entire rocket with a scratch filling sandable primer. Let dry, then sand with 220-grit sandpaper. Keep repeating the spraying and sanding process until all defects are gone. It is all right to sand through the primer except on the last primer coat. Also, the last primer coat may be sanded with even finer sandpaper. Even better is using a green 3M ScotchBrite pad.

Final Finishing/Painting

- Stay with the same brand of paint throughout the process; primer, base color, accent colors, and clear coat. Paints seem to work best as a "system", so use those from the same company to ensure compatibility.
- Four or five light coats are better than one or two heavy coats. You will reduce the risk of runs and sags in the paint dramatically, and it will dry faster as well.
- For the very first coat, apply a very light coat of your base color. You're really not trying for any color coverage at all, just getting a bit of the paint stuck to the surface of the rocket to allow the subsequent coats to bond to it. Allow this coat to dry for about 5 minutes before applying more coats. This first very light coat seems to "set the stage" for following coats so they won't run as easily.
- For the best finish, let each coat dry and sand lightly with 320 or 400 grit sandpaper; you should let each coat dry overnight before sanding. Also, wet sanding is best to sand paint because the water acts as a lubricant and a coolant, and flushes away the paint that's sanded off, keeping the sandpaper cleaner. Make sure you have sandpaper that's made for wet-sanding, and dip it in the water bucket at least every 30 seconds or so.
- Apply the last color coat as heavy as possible without running or sagging. There's no way to say how much is too much or too little; it's just something you develop with practice.
- Let the paint cure for at least 48 hours before handling! This is difficult to do, but will really pay off in the long run. Even though the paint feels dry, it is still quite soft underneath the top layer and will be easily damaged until it's fully cured.
- Once the paint has cured you can apply your decals or self-adhesive Monokote accent stripes (available at most hobby shops). Many hardware stores also carry various colors of vinyl tape, what most people call electrical tape.
- We recommend a clear coat of some sort to help protect the decals as well as "seal" their edges to help prevent them peeling off.

www.publicmissiles.com

The PML Web Store and Knowledge Base

Other items you will need:

One set of epoxy
One sheet each 120 and 220 sandpaper
Ruler and pencil

Masking tape
PML Expandable Liquid Foam (optional)
Wax paper

**Please read and understand all instructions before continuing!
All surfaces to be bonded must be scuffed with 120 grit sandpaper.**

Step 1

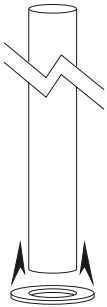

Epoxy the smallest centering ring (CR-3.9-2.1) up 1/2" from one end of the 24" long motor mount tube. Apply an epoxy fillet to both sides of the ring.

Allow motor mount tube to protrude 1/2"

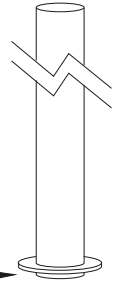

Step 2

- A) Holding the boat tail upright, place the motor mount tube (centering ring end down) into the boat tail. The centering ring should wedge slightly into the base of the boat tail before it reaches the bottom.
- B) Mix a 1 oz. batch of epoxy and pour it into the boat tail. Spread it over the centering ring so that it bonds to the boat tail. Quickly slip the 5-7/8" centering ring (the smaller of the two remaining rings) over the motor mount tube. Slide the ring down into the boat tail coupler just enough to center the motor mount tube. Leave it sticking out as much as possible because you will need to remove it later. Hold it in place with tape if necessary.
- Allow the epoxy to cure.

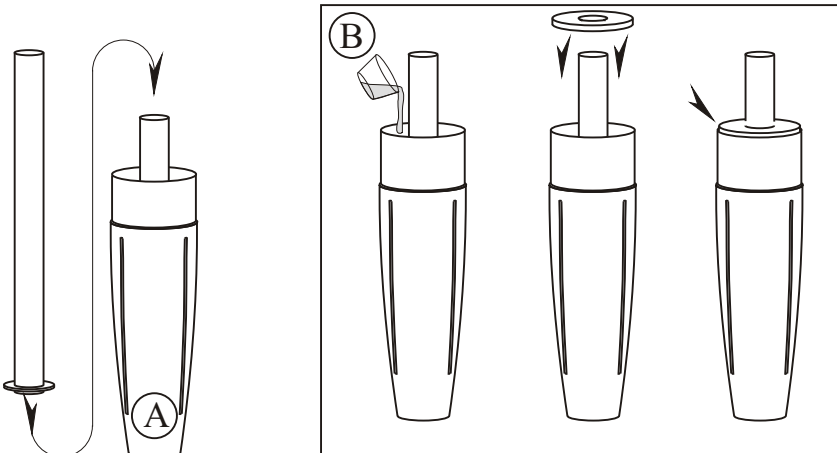

Step 3

A) Apply a bead of epoxy to the root edge of a fin. Push the fin through the slot in the airframe and against the motor mount tube. Make sure that the fin is perpendicular to the airframe. Use tape to hold the fin in position while the epoxy cures. Repeat this process for all fins.

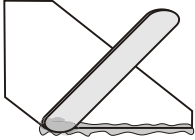

B) Apply an epoxy fillet to both sides of each fin. Carefully smooth the epoxy with your finger before it begins to gel. Allow the epoxy to set up before rotating the rocket to do the next set of fins. Once the epoxy has fully cured, you should sand the fillet smooth with fine sandpaper. Sanding will help the primer hold better to the epoxy.

C) Gently pull the centering ring off the motor tube. Using a stick, apply an epoxy fillet to the fins at the motor mount tube and the inner airframe wall. Replace the temporary centering ring just as it was in the previous step while the internal fillets cure.

Though not mandatory, a better method would be to use expandable liquid foam to encapsulate the entire fin root area. See the Liquid Foam instruction sheet for details or visit the Adhesives page of our website at www.publicmissiles.com.

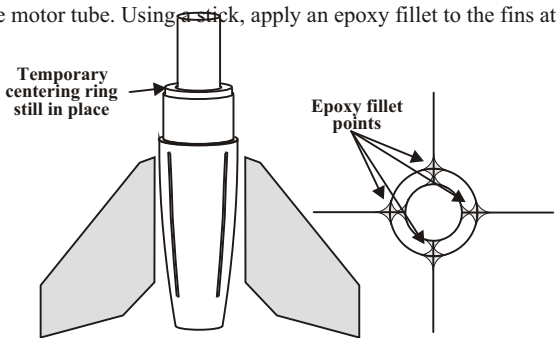

Step 4

Fins not shown for clarity

Remove the temporary centering ring. Spread a bead of epoxy around the circumference of the motor tube and on the inside of the boattail shoulder near the top. Slide the ring back in place but this time make it flush with the end of the boattail shoulder. Spread a bead of epoxy around the circumference of the motor tube, 1/2" from the top, leaving a 1" gap in the bead for the notch in the centering ring. Slip the notched centering ring over the motor tube with the notch aligned with the gap in the epoxy bead. Be sure the notch in the ring remains clear of epoxy. Locate the ring 1/2" from the end of the motor tube and allow the epoxy to set. Apply an epoxy fillet to each side of the ring still keeping the notch clear.

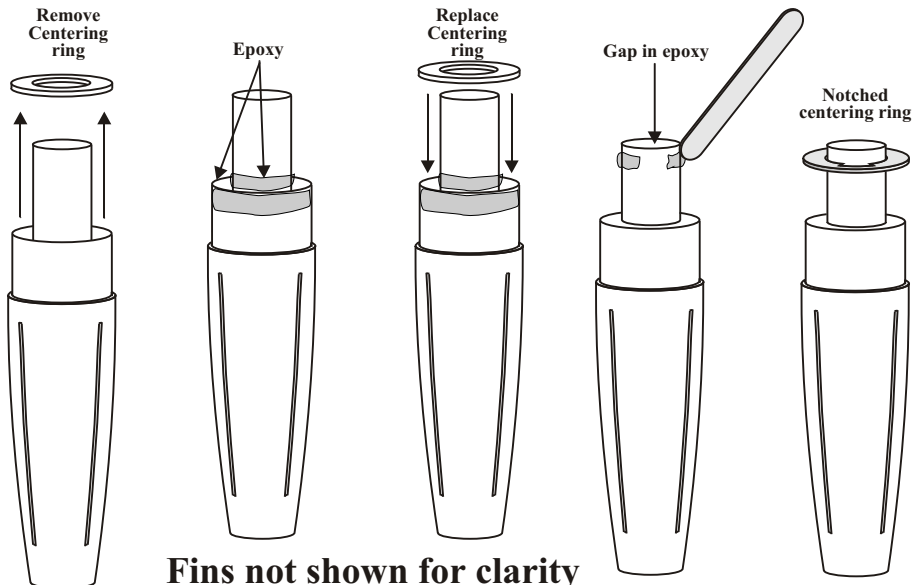

Step 5

Fins not shown for clarity

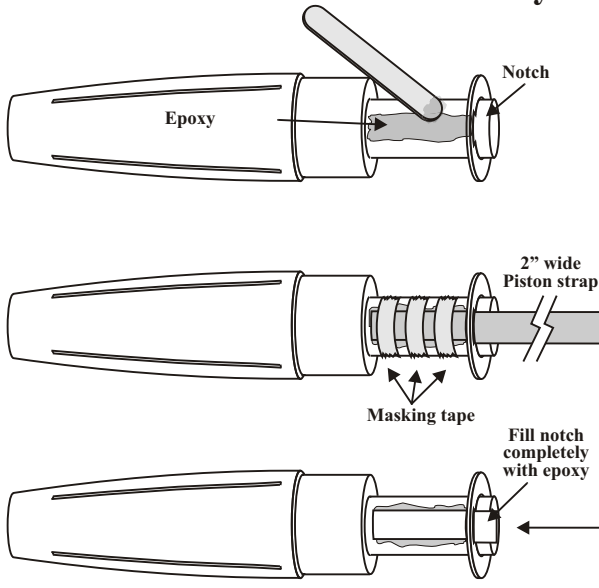

NOTE: The piston strap is the 2" wide strap that looks like a seatbelt. Spread a layer of epoxy about 2" wide on the motor tube just below the notch in the upper centering ring. Slip one end of the piston strap (the widest strap in the kit) through the notch in the centering ring. Pull through about 4" of this strap through the notch and press it firmly into the epoxy on the side of the motor tube. Hold the strap in place against the tube with masking tape until the epoxy cures. Remove the masking tape. **Fill the entire centering ring notch with epoxy.** Stuff the free end of the strap into the motor tube to keep it out of the way for the next step.

Stuff piston strap into motor tube to keep it out of the way for the next step.

Step 6

1) Apply a bead of epoxy to the root edge of a fin. Push the fin into the dado groove in the airframe. Make sure that the fin is perpendicular to the airframe. Use tape to hold the fin in position while the epoxy cures. Repeat this process for all fins.

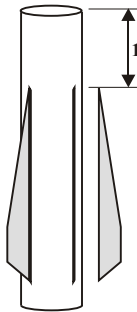

2) Apply an epoxy fillet to both sides of each fin. Carefully smooth the epoxy with your finger before it begins to gel. Allow the epoxy to set-up before rotating the rocket to do the next set of fins. Once the epoxy has fully cured, you should sand the fillet smooth with 220 grit sandpaper. Sanding will help the primer hold better to the epoxy.

Step 7

Apply a heavy layer of epoxy to the inside circumference of the main airframe at the bottom end and another 9" in from the bottom. Tip the tail section into the main airframe as shown to get the centering ring past the first ring of epoxy then straighten it as you continue to push it into the airframe. Align the upper and lower fins. Stand the assembly upright and allow the epoxy to cure.

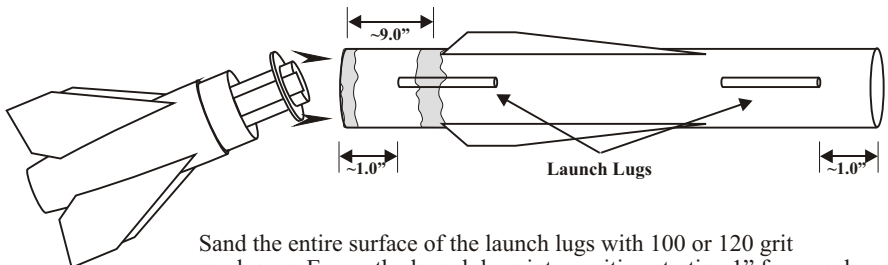

Sand the entire surface of the launch lugs with 100 or 120 grit sandpaper. Epoxy the launch lugs into position starting 1" from each end of the main airframe. Be sure the lugs are perfectly in line with each other, not in line with the fins and are parallel to the airframe.

Step 8

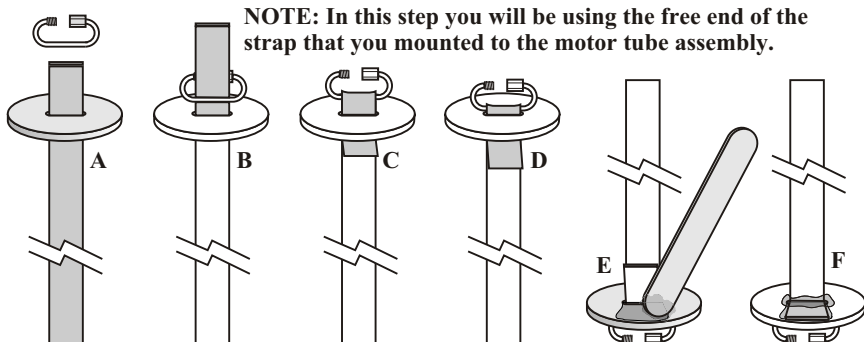

NOTE: In this step you will be using the free end of the strap that you mounted to the motor tube assembly.

- A)** Pull the free end of the strap through the slot in the piston bulk plate.
B) Slip the metal "Kwik Link" ring over the strap.
C) Feed the strap back through the slot.
D) Pull on the strap until the "Kwik Link" ring is wedged at the slot.
E) Flip the assembly over. Spread a layer of epoxy on the underside of the piston plate as shown. Fold the short end of the strap flat against the piston plate and press it into the epoxy. You can use a clamp to hold the strap in the epoxy while it sets.
F) When the epoxy has cured, pull the strap until the "Kwik Link" ring is wedged tight at the slot. Apply epoxy to the strap at the "Kwik Link" ring.
G) Epoxy the piston plate inside the piston body 1/4" from the top.
H) Apply an epoxy fillet to both sides of the piston plate.

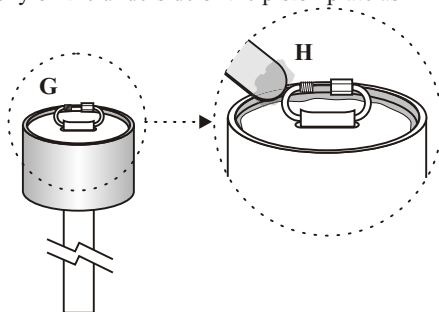

Step 9

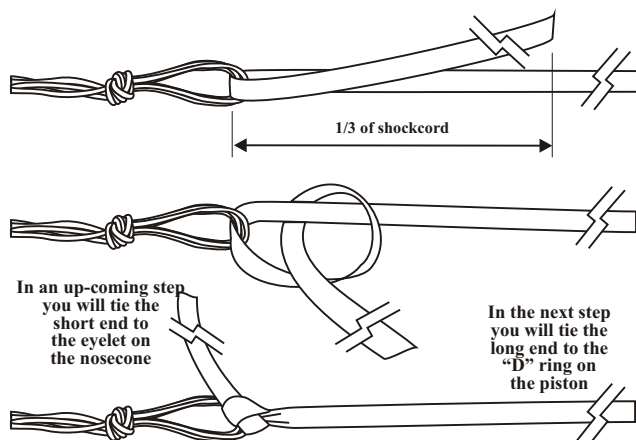

Prepare the parachute per the parachute instructions. Thread the shock cord through the loop you made in the parachute shroud lines and tie it using the knot illustrated on the left. Note that the chute should be attached to the shock cord at about the 1/3 point of the shock cord. Alternatively, you can tie the shock cord to a "kwik-link" and then attach the "kwik-link" to the loop in the shroud lines.

In an up-coming step you will tie the short end to the eyelet on the nosecone

In the next step you will tie the long end to the "D" ring on the piston

Step 10

Thread the long end of the shock cord through the “Kwik Link” and tie it using the knot illustrated below.

Use the same knot to tie the other end of the shock cord to the U-bolt of the nosecone (below).

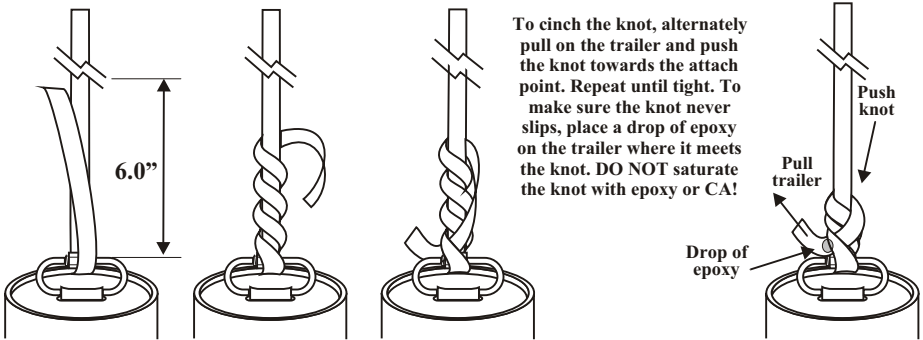

Step 11

Assemble the u-bolt assembly in the order shown below. Be sure the nuts are tight. Loctite can and should be used to make sure the nuts do not come loose.

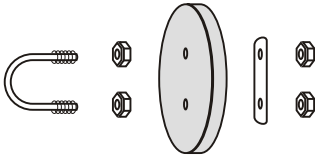

Epoxy the bulkhead assembly into the nosecone shoulder about 1/4" below the edge. Apply an epoxy fillet around the circumference of the bulkhead.

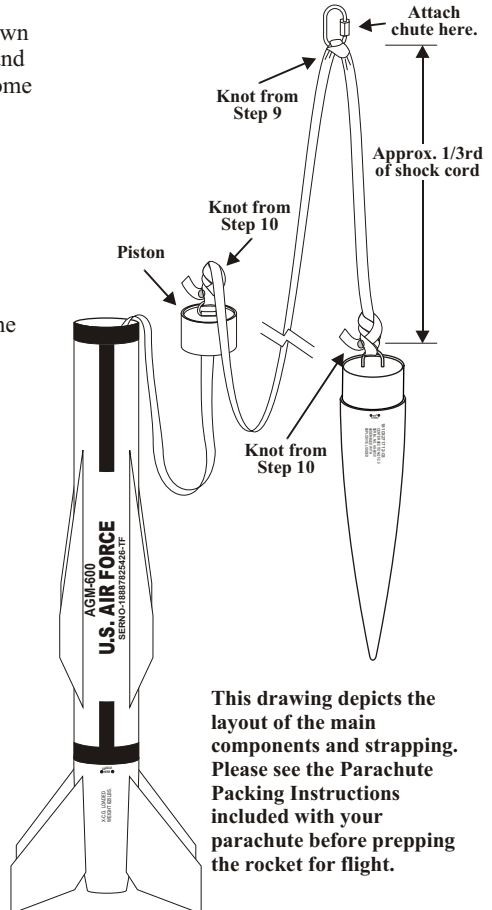
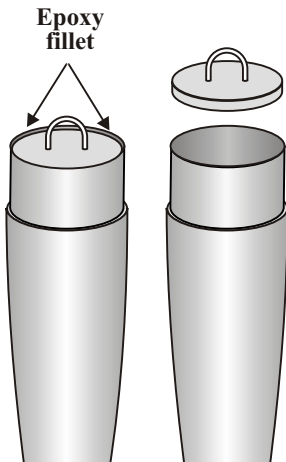

AGM-600 U.S. AIR FORCE SERNO-18887825426-TF

AGM-600 U.S. AIR FORCE SERNO-18887825426-TF

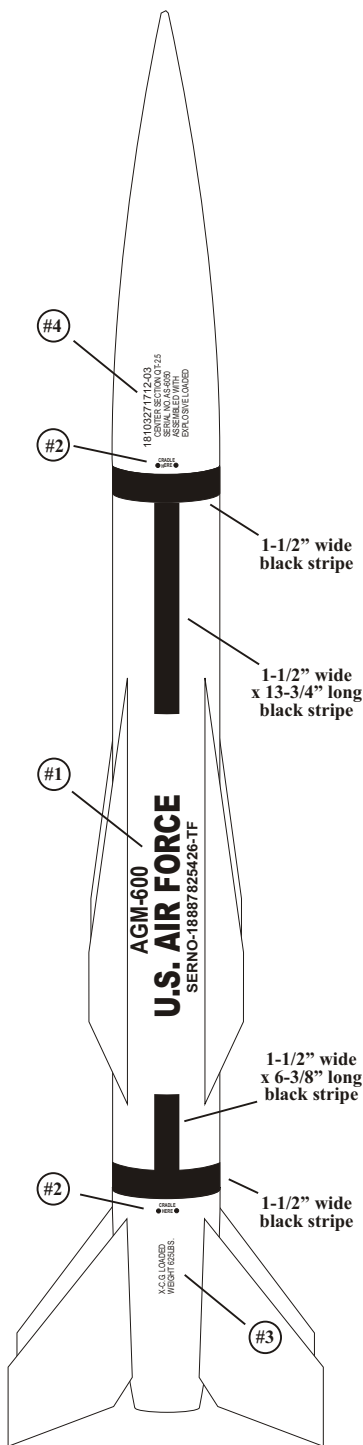

#4
18103271712-03
CENTER SECTION QT-2.5
SERIAL NO. AS-6050
ASSEMBLED WITH
EXPLOSIVE LOADED

X-C.G. LOADED
WEIGHT 625LBS.

X-C.G. LOADED
WEIGHT 625LBS.

X-C.G. LOADED
WEIGHT 625LBS.

#4
18103271712-03
CENTER SECTION QT-2.5
SERIAL NO. AS-6050
ASSEMBLED WITH
EXPLOSIVE LOADED

#3
X-C.G. LOADED
WEIGHT 625LBS.



First paint the entire rocket white. Two opposite sides of the rocket are identical. Black stripes can be painted on or you can use self-stick black Mono-Kote (r). Decals as shown are 90 degrees from the launch lug side of the rocket. Decals #2 and #7 are located on all 4 sides of the rocket. Decals #3 are on the airframe tube flush with the tube ends.



www.publicmissiles.com

The PML Web Store and Knowledge Base

Revised 7.06.06